

# EQUIPOS DE REFRIGERACIÓN



Esenciales para mantener la frescura y calidad de tus productos



[dmaryexpress.com](http://dmaryexpress.com)



[logistica@dmaryexpress.com](mailto:logistica@dmaryexpress.com)



+507 6128 0684

DM

**EUROPEAN STYLE**  
COUNTER REFRIGERATOR FAN COOLING

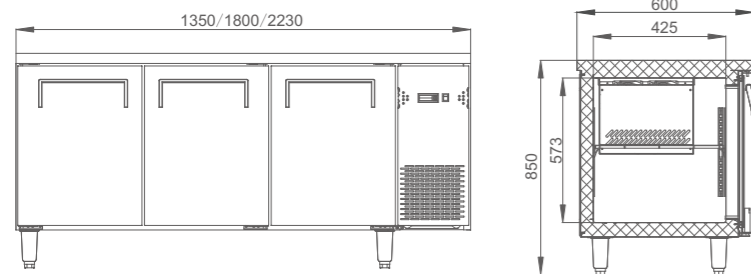

**Product Features**

- Self-closing door design
- Fan cooling design
- Digital thermostat for precise temperature control

SN1350TN/SN1350BT/SN1800TN/SN1800BT/SN2230TN/SN2230BT

Model	Product Dimension WxDxH(mm)			Packing Dimension WxDxH(mm)			Temperature	Capacity (Litre)	Doors	40HQ Loading
SN1350TN	1350			1410			0°C≤t≤10°C	248	2	78
SN1350BT							-18°C≤t≤-6°C			
SN1800TN	1800	600	850	1860	660	880	0°C≤t≤10°C	365	3	57
SN1800BT							-18°C≤t≤-6°C			
SN2230TN	2230			2290			0°C≤t≤10°C	473	4	54
SN2230BT							-18°C≤t≤-6°C			

**EUROPEAN STYLE**  
COUNTER REFRIGERATOR FAN COOLING

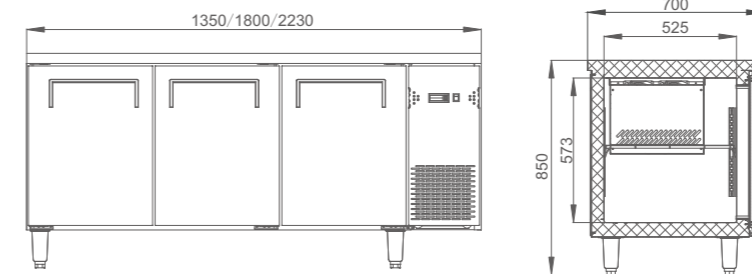

**Product Features**

- Self-closing door design
- Fan cooling design
- Digital thermostat for precise temperature control

GN1350TN/GN1350BT/GN1800TN/GN1800BT/GN2230TN/GN2230BT

Model	Product Dimension WxDxH(mm)			Packing Dimension WxDxH(mm)			Temperature	Capacity (Litre)	Doors	40HQ Loading
GN1350TN	1350			1410			0°C≤t≤10°C	302	2	72
GN1350BT							-18°C≤t≤-6°C			
GN1800TN	1800	700	850	1860	760	880	0°C≤t≤10°C	445	3	57
GN1800BT							-18°C≤t≤-6°C			
GN2230TN	2230			2290			0°C≤t≤10°C	577	4	45
GN2230BT							-18°C≤t≤-6°C			

**EUROPEAN STYLE  
REACH-IN REFRIGERATOR/FREEZER**

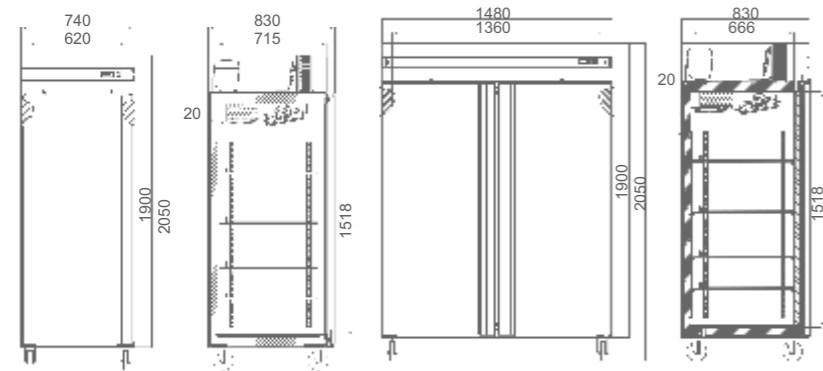

GN650BT / GN1420BT

Model	Product Dimension WxDxH(mm)			Packing Dimension WxDxH(mm)			Temperature	Capacity (Litre)	Doors	40HQ Loading
GN650TN	740	830	2050	775	870	2100	2°C≤t≤8°C	652	1	39
GN650BT							-22°C≤t≤-18°C			
GN1420TN	1480	830	2050	1530	870	2100	2°C≤t≤8°C	1424	2	15
GN1420BT							-22°C≤t≤-18°C			

**SLIM MOTOR ROOM UNDERCOUNTER**



RT-12SM  
FT-12SM



RT-15SM  
FT-15SM



RT-18SM  
FT-18SM



Front out air flow

Front in air flow

FRONT & FRONT-OUT AIR FLOW

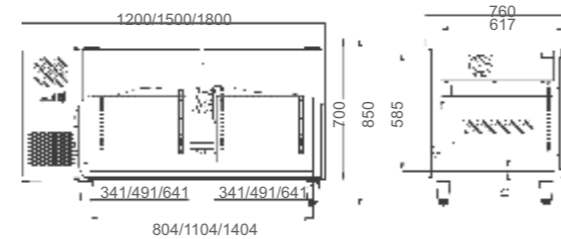

RT-12SM / RT-15SM / RT-18SM

Model	Product Dimension WxDxH(mm)		Packing Dimension WxDxH(mm)		Temperature	Capacity (Litre)	Doors	40HQ Loading
RT-12SM	1200	760	1260	820				
RT-15SM	1500		1560		880			
RT-18SM	1800	1860						
FT-12SM	1200	760	1260	820	-22°C≤t≤-6°C	350	2	45
FT-15SM	1500		1560					
FT-18SM	1800	1860						

**Product Features**

- Small motor room
- Large storage space
- Space Saving Solution
- Hi-quality stainless steel
- Hi-efficiency compressor

**COUNTER REFRIGERATOR**  
FAN COOLING

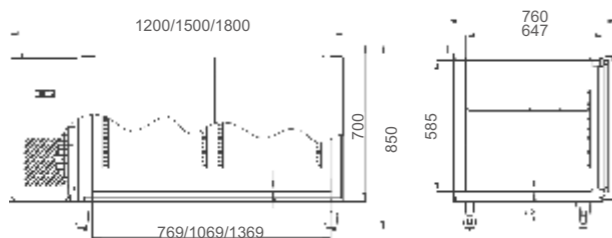

RT-12V / RT-15V / RT-18V

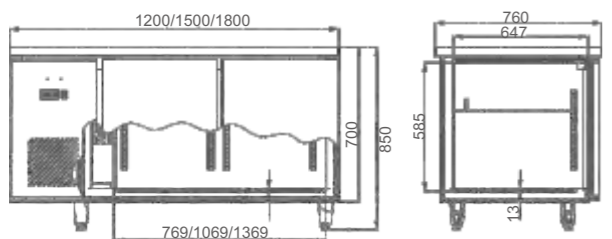

FT-12V / FT-15V / FT-18V

**Product Features**

- Digital thermostat
- Self-closing doors
- Glass door optional
- Hi-efficiency compressor
- Adjustable feet/universal casters
- Fan cooling system ,automatic defrost

**COUNTER REFRIGERATOR**  
STATIC COOLING

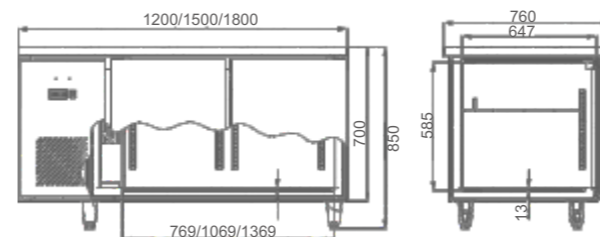

RT-12S / RT-15S / RT-18S

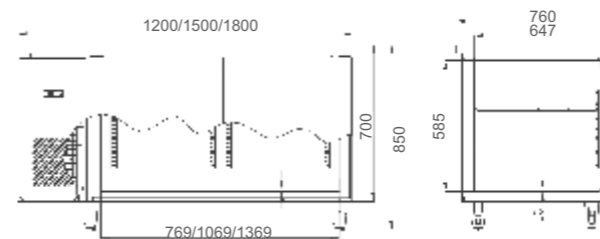

FT-12S / FT-15S / FT-18S

**Product Features**

- Self-closing doors
- Glass door optional
- Static system with copper pipe
- Adjustable foot/castors

Model	Product Dimension WxDxH(mm)		Packing Dimension WxDxH(mm)		Temperature	Capacity (Litre)	Doors	40HQ Loading
RT-12V	1200	600/700/760	800/850	830	0°C≤t≤10°C	274	2	69
RT-15V	1500					382		45
RT-18V	1800					490	42	
FT-12V	1200	600/700/760	800/850	830	-22°C≤t≤-18°C	274	2	69
FT-15V	1500					382		45
FT-18V	1800					490	42	

Model	Product Dimension WxDxH(mm)		Packing Dimension WxDxH(mm)		Temperature	Capacity (Litre)	Doors	40HQ Loading
RT-12S	1200	600/700/760	800/850	830	0°C≤t≤10°C	274	2	69
RT-15S	1500					382		45
RT-18S	1800					490	42	
FT-12S	1200	600/700/760	800/850	830	-18°C≤t≤-15°C	274	2	69
FT-15S	1500					382		45
FT-18S	1800					490	42	

**COMMERCIAL REFRIGERATOR**  
FAN COOLING

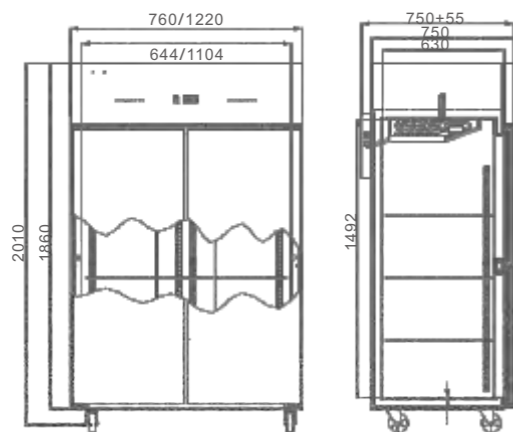

U7R2V / U7F2V

**Product Features**

- Digital thermostat
- Self closing doors
- Glass door is optional
- Hi-efficiency compressor
- Adjustable feet/universal casters
- Fan cooling system ,automatic defrost

Model	Product Dimension WxDxH(mm)			Packing Dimension WxDxH(mm)			Temperature	Capacity (Litre)	Doors	40HQ Loading
U7R2V	760	760	2010	830	830	2070	0°C≤t≤10°C	637	2	28
U7F2V							-18°C≤t≤-15°C			
U12R4V	1220	760	2010	1280	830	2070	0°C≤t≤10°C	1081	4	23
U12F4V							-18°C≤t≤-15°C			

**COMMERCIAL REFRIGERATOR ECONOMY**  
STATIC COOLING

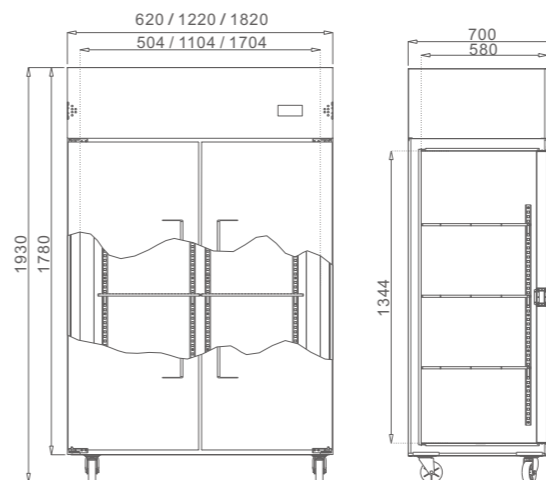

HF1.0S

**Product Features**

- Self-closing door
- Glass door optional
- Mechanical thermostat
- Adjustable feet/casters
- Static system with copper pipe

Model	Product Dimension WxDxH(mm)			Packing Dimension WxDxH(mm)			Temperature	Capacity (Litre)	Doors	40HQ Loading
HR0.5S	620	700	1930	700	750	2000	-5°C≤t≤5°C	392	2	45
HR1.0S	1220			1270				858	4	27
HR1.6S	1820			1870				1324	6	19
HF0.5S	620	700	1930	700	750	2000	-15°C≤t≤-10°C	392	2	45
HF1.0S	1220			1270				858	4	27
HF1.6S	1820			1870				1324	6	19
HRF1.0S	1220	700	1930	1270	750	2000	0°C≤t≤10°C/ -15°C≤t≤-10°C	404x2	4	27
HRF1.6S	1820			1870				624x2	6	19

# DISPLAY CHILLER BOTTOM MOUNTED

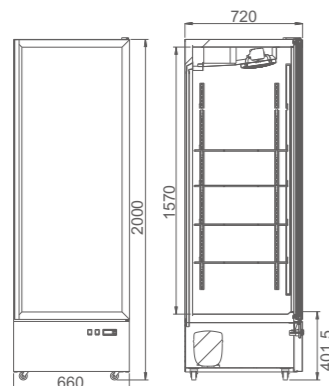
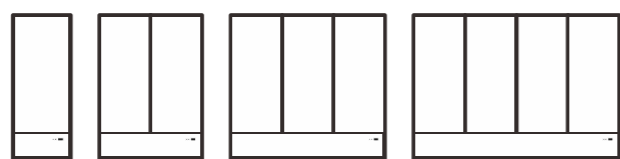

LG4-520WP

## Product Features

- Drainage
- Low-E glass
- Digital thermostat
- Automatic defrost
- Self-closing doors
- Internal LED light
- Air cooled condenser
- Hi-efficiency compressor

Model	Product Dimension WxDxH(mm)		Packing Dimension WxDxH(mm)			Temperature	Capacity (Litre)	Shelf Quantity	40HQ Loading
LG-380WP	600	600	650	650	2065	0°C ≤ t ≤ 10°C	380	4	54
LG-520WP	660	700					760		51
LG-960M2WP	1250	1310	780	2110	960		8	27	
LG-1480M3WP	1880				1940		18		
LG-2000M4WP	2500				2560		2000	16	12

# DISPLAY FREEZER BOTTOM MOUNTED

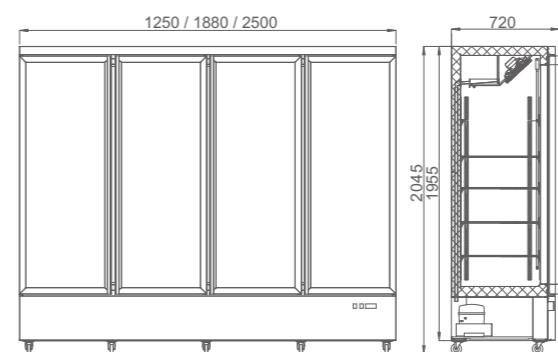
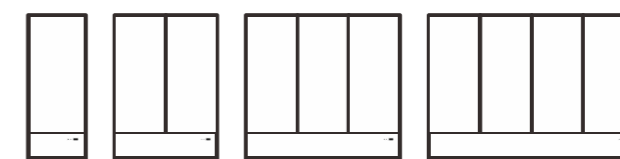

LD-920M2WP / LD-1430M3WP / LD-1940M4WP

## Product Features

- Digital thermostat
- Automatic defrost
- Internal LED light
- Self-closing doors
- Air cooled condenser
- High temperature alarm
- Hi-efficiency compressor
- Automatic fan switch off with door opening

Model	Product Dimension WxDxH(mm)		Packing Dimension WxDxH(mm)			Temperature	Capacity (Litre)	Shelf Quantity	40HQ Loading
LD-340WP	600	600	650	650	2065	t ≤ -22°C	340	4	54
LD-470WP	660	700					760		51
LD-920M2WP	1250	1310	780	2110	920		8	27	
LD-1430M3WP	1880				1940		18		
LD-1940M4WP	2500				2560		1940	16	12

**DISPLAY CHILLER**  
FAN COOLING

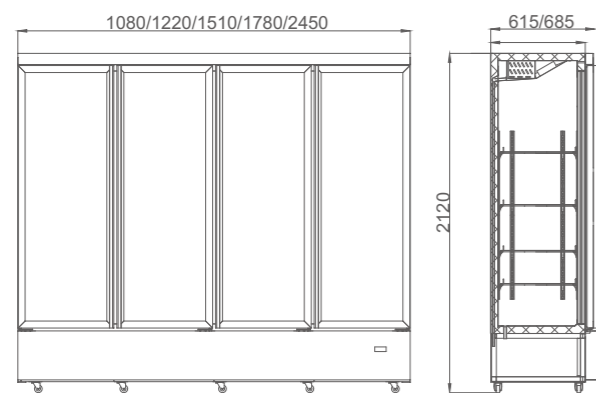

LG-882M2/WP / LG-1000M2/WP / LG-1200M3/WP / LG-1400M3/WP / LG-1800M4/WP

**Product Features**

- Plug ready
- High aesthetics
- Maximum utilization of product loading space
- Large display area optimum product promotion
- Ideal for Supermarkets ,mini markets, Convenience stores

Model	Product Dimension WxDxH(mm)		Packing Dimension WxDxH(mm)		Temperature	Capacity (Litre)	Shelf Quantity	40HQ Loading
LG-882M2/WP	1080	615	1150	670				
LG-1000M2/WP	1220	685	1280	740	830	27		
LG-1200M3/WP	1510		1570		12	1030	23	
LG-1400M3/WP	1780		1840			1230	19	
LG-1800M4/WP	2450	2510	1800	16	12			

**DISPLAY CHILLER**  
FAN COOLING

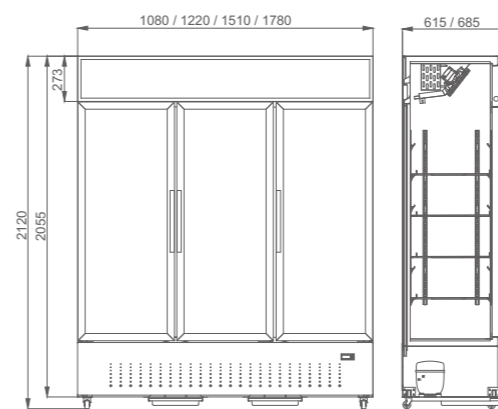

LG-882M2W / LG-1000M2W / LG-1200M3W / LG-1400M3W

**Product Features**

- Plug ready
- Reliable and functional
- Optimum product visibility
- Top cooling capacity ideal for perishable products
- Shelving solutions suitable for each customer' s needs
- Selected by leading companies in the dairy and beverage sector
- Ideal for the conservation and promotion of bottled and packed products

Model	Product Dimension WxDxH(mm)		Packing Dimension WxDxH(mm)		Temperature	Capacity (Litre)	Shelf Quantity	40HQ Loading
LG-882M2W	1080	615	1150	665				
LG-1000M2W	1220	685	1280	740	830	27		
LG-1200M3W	1510		1570		12	1030	23	
LG-1400M3W	1780		1840			1230	19	
LG-1800M4W	2450	2510	1800	16	12			

# DISPLAY CHILLER ECONOMY

## FAN COOLING

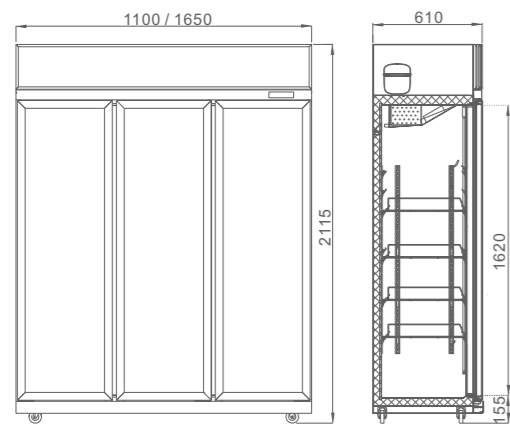

LG4-1100LW / LG4-1650LW

### Product Features

- Plug ready
- Ideal for heavy duty
- Ideal for small places
- Reliable and functional
- Optimum product visibility
- Top cooling capacity ideal for perishable products
- Shelving solutions suitable for each customer's needs
- Selected by leading companies in the dairy and beverage sector
- Ideal for the conservation and promotion of bottled and packed products

Model	Product Dimension WxDxH(mm)			Packing Dimension WxDxH(mm)			Temperature	Capacity (Litre)	Shelf Quantity	40HQ Loading
LG4-1100LW	1100	660	2115	1180	740	2310	0°C ≤ t ≤ 10°C	705	8	32
LG4-1650LW	1650			1730						



# DISPLAY CHILLER

## SUPERMARKET COMBINATION-NO FROST

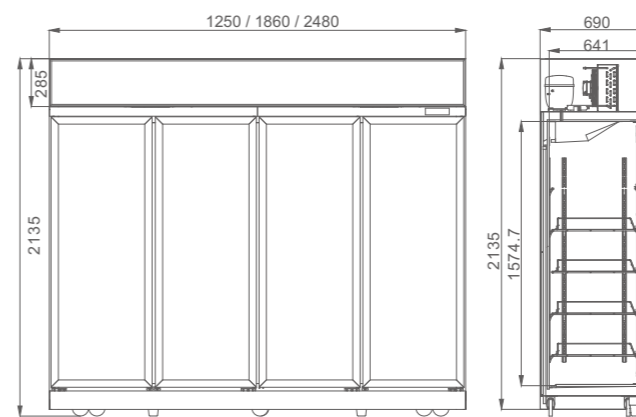

LG4-1160M2W / LG4-1860M3W / LG4-2360M4W

### Product Features

- Fan cooling
- Digital thermostat
- Splittype optional
- Automatic defrost
- Large storage volume
- Tempered glass with heating film

Model	Product Dimension WxDxH(mm)			Packing Dimension WxDxH(mm)			Temperature	Capacity (Litre)	Shelf Quantity	40HQ Loading
LG4-1160M2W	1250	745	2135	1350	785	2275	0°C ≤ t ≤ 10°C	960	8	23
LG4-1860M3W	1860			1960						
LG4-2360M4W	2480			2690						

# FRAMELESS DISPLAY CHILLER

## FAN COOLING



# DISPLAY FREEZER

## BOTTOM MOUNTED

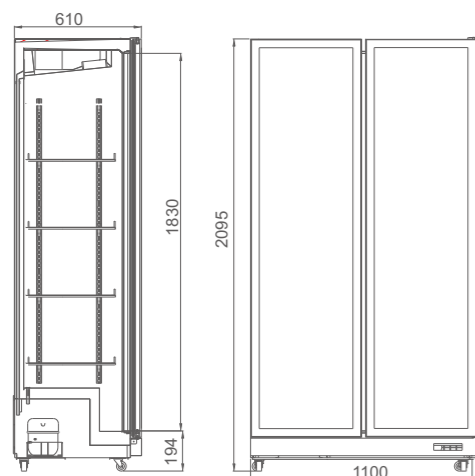

LG4-1100LW-A

### Product Features

- Drainage
- Low-E glass
- Digital thermostat
- Self-closing doors
- Automatic defrost
- Internal LED light
- Air-cooled condenser
- Hi-efficiency compressor

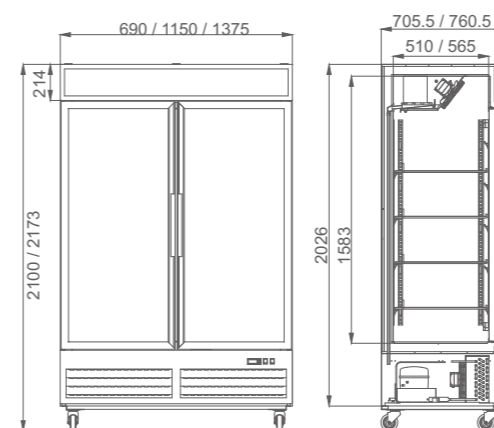

LD-460W / LD-800M2W / LD-1040M2W

### Product Features

- Digital thermostat
- Operation switch
- Self closing door
- Automatic defrost
- Internal LED light
- Easily removable grill
- Air cooled condenser
- Hi-efficiency compressor
- Antidazzle safety glass door
- Automatic fan switch off with door opening

Model	Product Dimension WxDxH(mm)			Packing Dimension WxDxH(mm)			Temperature	Capacity (Litre)	Shelf Quantity	40HQ Loading
LG4-1100LW-A	1100	610	2095	1220	740	2180	0°C≤t≤10°C	850	8	28
LG4-1650LW-A	1650			1770				1300	12	19

Model	Product Dimension WxDxH(mm)			Packing Dimension WxDxH(mm)			Temperature	Capacity (Litre)	Shelf Quantity	40HQ Loading
LD-460W	690	750	2100	735	770	2250	t≤-22°C	460	4	45
LD-800M2W	1150			1190				800	8	30
LD-1040M2W	1375	805	2175	1430	835	2270		1040	8	22

# DISPLAY CHILLER WITH SLIDING DOOR BOTTOM MOUNTED

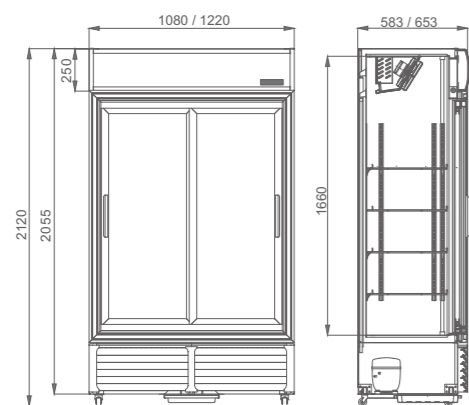

LGF-800S / LGF-1000S

## Product Features

- Low noise
- Self-closing doors
- Low energy consumption
- Customer friendly operation
- Product planogram flexibility
- LED light for optimum product illumination
- Slim door frame for enhanced product visibility

# BACKBAR COOLER

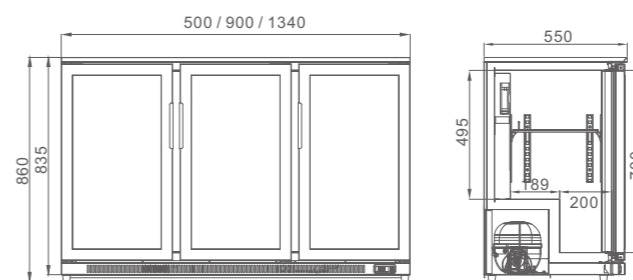

BBC-1 / BBC-2 / BBC-3

## Product Features

- LED product illumination
- Stainless steel cabinet optional
- Electronic thermostat with display
- Ideal size for behind & under the bar placement

Model	Product Dimension WxDxH(mm)			Packing Dimension WxDxH(mm)			Temperature	Capacity (Litre)	Shelf Quantity	40HQ Loading
BBC-1	500			560			0°C ≤ t ≤ 10°C	98	2	212
BBC-2	900	550	860	960	610	930		191	4	110
BBC-3	1340			1400				295	6	78

# REFRIGERATED MULTIDECK

## FAN COOLING

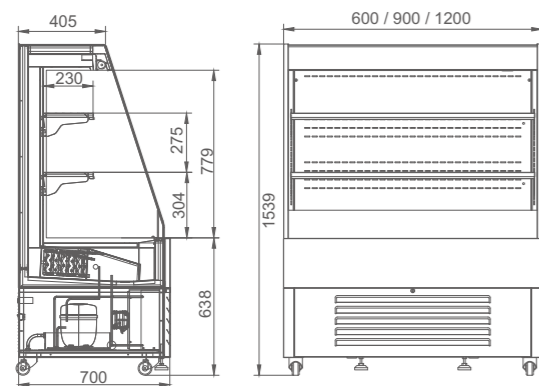

DLCD-6PF / DLCD-9PF / DLCD-12PF

### Product Features

- LED light
- Elegant appearance design
- Copper evaporator & condenser
- Stainless steel cabinet is optional
- Hi-efficiency compressor and fan
- Built-in stainless steel water drain tray

Model	Product Dimension WxDxH(mm)			Packing Dimension WxDxH(mm)			Temperature	Capacity (Litre)	Shelf Quantity	40HQ Loading
DLCD-6PF	600	700	1539	700	770	1630	2°C≤t≤8°C	206	2	51
DLCD-9PF	900			1000				311		35
DLCD-12PF	1200			1300				416		27

# DISPLAY CHILLER

## STATIC COOLING WITH FAN

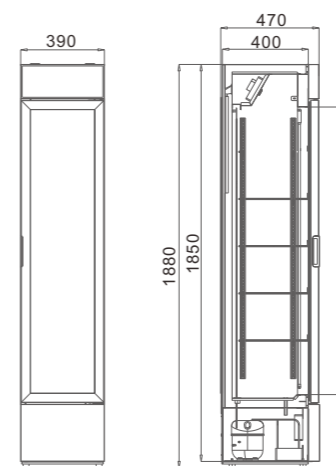

LGZ-150W

### Product Features

- Durable adjustable feet
- Adjustable shelves for easy cleaning
- Hi-efficiency LED product illumination
- Fan cooling system assisted ( For Option)
- Small footprint combined with slim design fits every outlet and drives impulse buying

Model	Product Dimension WxDxH(mm)			Packing Dimension WxDxH(mm)			Temperature	Capacity (Litre)	Shelf Quantity	40HQ Loading
LGZ-150W	390	470	1880	450	540	1930	0°C≤t≤10°C	150	4	140

**DISPLAY CHILLER**  
FAN COOLING

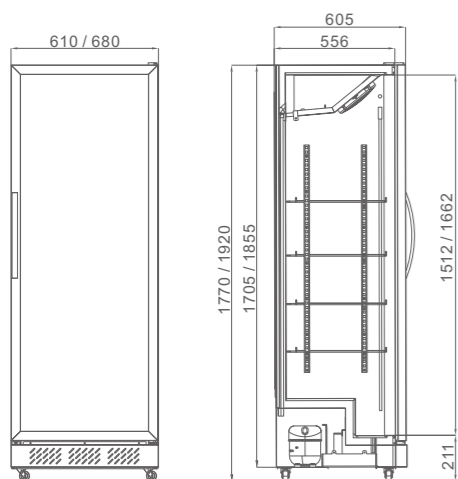

LGT-350WL / LGT-460WL

**Product Features**

- Plug ready
- Ideal for small places
- Top quality Low-E glass
- Optimum product visibility
- Interior LED light with switch
- Adjustable shelves for easy cleaning
- Digital controller and temperature display
- Modern and elegant design without canopy
- Special step design at the bottom maximizes inside storage space

Model	Product Dimension WxDxH(mm)		Packing Dimension WxDxH(mm)			Temperature	Capacity (Litre)	Shelf Quantity	40HQ Loading
LGT-350WL	610	650	1770	665	685	0°C≤t≤10°C	350	4	73
LGT-460WL	680		1920	740					1970

**DISPLAY CHILLER**  
FAN COOLING

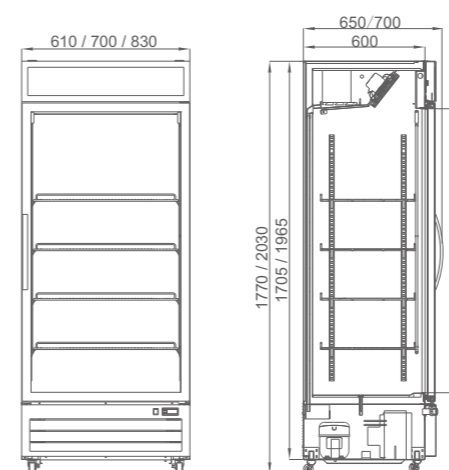

LGX-316WL / LGX-426WL / LGX-505WL / LGX-610WL

**Product Features**

- Plug ready
- Ideal for small places
- Top quality Low-E glass
- Replaceable door gasket
- Optimum product visibility
- Elegant louvre panel design
- Adjustable shelves for easy cleaning
- Digital controller and temperature display

Model	Product Dimension WxDxH(mm)			Packing Dimension WxDxH(mm)		Temperature	Capacity (Litre)	Shelf Quantity	40HQ Loading
LGX-316WL	610	650	1770	660	685	0°C≤t≤10°C	316	3	73
LGX-426WL							426		54
LGX-505WL	700	700	2030	750	735	0°C≤t≤10°C	505	4	48
LGX-610WL	830						880		2150

# DISPLAY CHILLER

## FAN COOLING

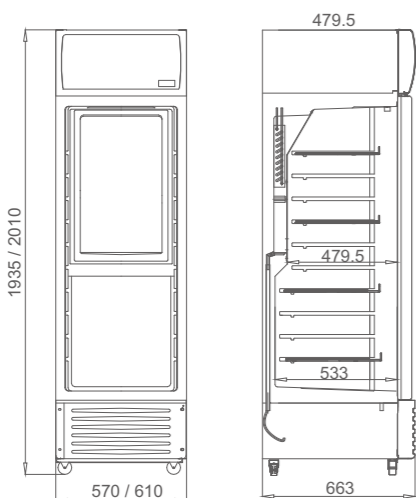

LG-350W / LG-400W

### Product Features

- No frost
- HIPS Interior
- Automatic defrost
- Digital thermostat
- Adjustable shelves
- BIG canopy design
- 100% CFC free polyurethane foam

# MINI DISPLAY CHILLER

## STATIC COOLING

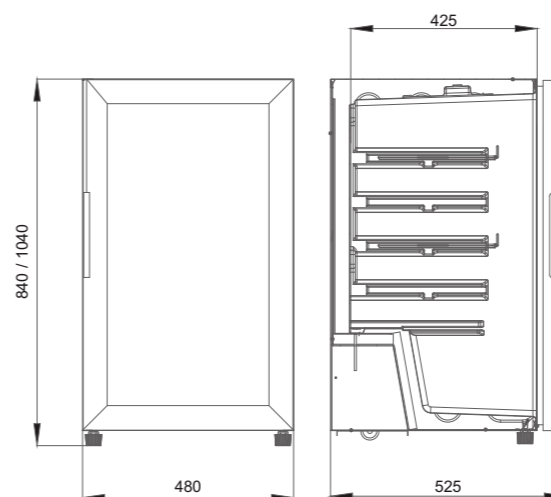

LGZ-120 / LGZ-160

### Product Features

- Ideal for office use
- Fits every outlet & counter flexible
- Eye catching various options driving impulse buying
- Easy to relocate unit optimal footprint combined with high capacity

Model	Product Dimension WxDxH(mm)		Packing Dimension WxDxH(mm)			Temperature	Capacity (Litre)	Shelf Quantity	40HQ Loading
LG-350W	570	663	1935	635	730	0°C≤t≤10°C	272	4	72
LG-400W	610		2010	680			2080		312

Model	Product Dimension WxDxH(mm)		Packing Dimension WxDxH(mm)			Temperature	Capacity (Litre)	Shelf Quantity	40HQ Loading
LGZ-120	480	525	840	530	582	0°C≤t≤10°C	120	3	258
LGZ-160			1040						1080

# COUNTER TOP FREEZER

Freezer temperature range:  $t \leq -22^{\circ}\text{C}$

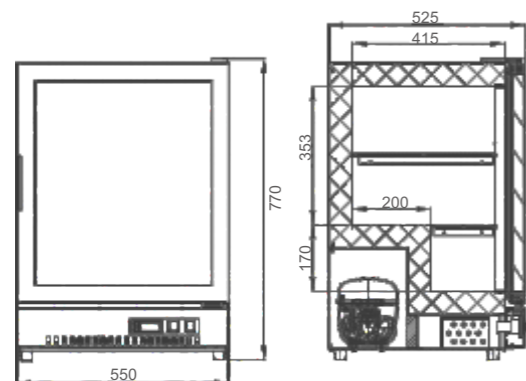

LD-80

## Product Features

- Plug ready
- Digital thermostat
- Internal LED light
- Heavy duty design
- Maximum use of limited spaces
- Copper evaporator & condenser
- Ideal for promoting frozen products
- Triple-layer tempered glass with heating film

Model	Product Dimension WxDxH(mm)			Packing Dimension WxDxH(mm)			Temperature	Capacity (Litre)	Shelf Quantity	40HQ Loading
LD-80	550	525	770	600	575	810	$t \leq -22^{\circ}\text{C}$	80	2	240

# SUPERMARKET ISLAND FREEZER

AUTO-DEFROST



## DIAGRAMMATIC SKETCH

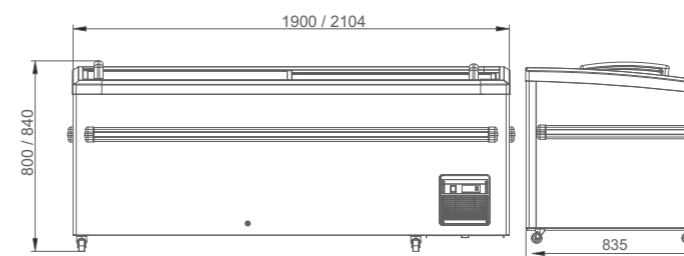
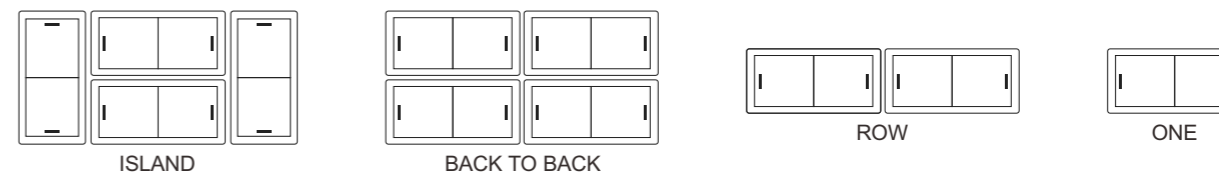

WD4-558 / WD4-758

## Product Features

- Plug ready
- Digital thermostat
- Reliable and functional
- Ideal height-Excellent product display
- Selected by leading companies in the frozen food sector and super markets

Model	Product Dimension WxDxH(mm)			Packing Dimension WxDxH(mm)			Temperature	Capacity (Litre)	Shelf Quantity	40HQ Loading
WD4-558	1900	835	800	1986	935	930	$t \leq -18^{\circ}\text{C}$	568	6	24
WD4-758	2104		840	2225		960		758		

## CURVED GLASS DOOR ISLAND FREEZER



WD4-1008



WD4-428



WD4-768



WD4-538

### DIAGRAMMATIC SKETCH

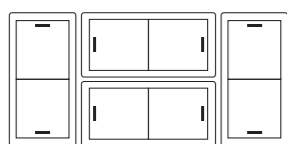

ISLAND

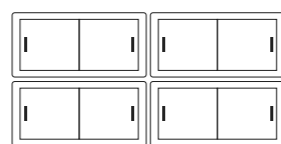

BACK TO BACK

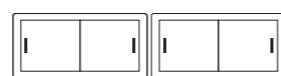

ROW

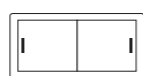

ONE

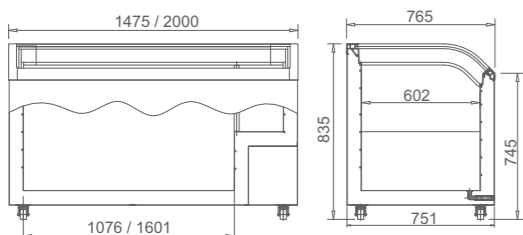

WD4-538 / WD4-768

### Product Features

- Adjustable baskets
- LED light is optional
- Heat reflection glass
- Maximizes food presentation
- 100% CFC free polyurethane foam
- WD4-1008 in Double open side design

Model	Product Dimension WxDxH(mm)			Packing Dimension WxDxH(mm)			Temperature	Capacity (Litre)	Shelf Quantity	40HQ Loading
WD4-538	1475			1530			0°C ≤ t ≤ 10°C or t ≤ -18°C	468	5	56
WD4-768	2000	765	835	2060	810	880		548	7	42
WD4-428	1615			1670				428	5	
WD4-1008	2000	1000	895	2050	1080	1010		750	6	22

## ISLAND FREEZER FLAT GLASS TOP

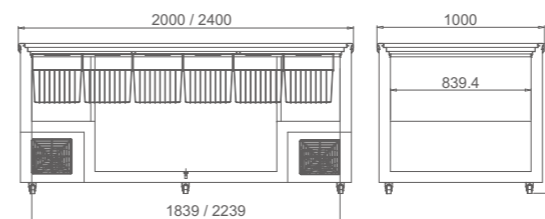

WD4-898 / WD4-1098

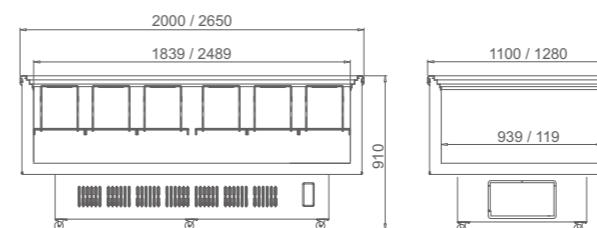

WD4-960 / WD4-1260

### Product Features

- Plug ready
- Ideal for heavy duty
- Reliable and functional
- Optimum product visibility
- Ideal for promoting frozen products
- Selected by leading companies in the ice cream sector

Model	Product Dimension WxDxH(mm)			Packing Dimension WxDxH(mm)			Temperature	Capacity (Litre)	Shelf Quantity	40HQ Loading
WD4-960	2000	1100	910	2040	1140	980	t ≤ -18°C	960	6	22
WD4-1260	2650	1280		2690	1320			8		
WD4-898	2000	1000	900	2050	1060	950		898		20
WD4-1098	2400			2450				1098		22

# ICE CREAM FREEZER

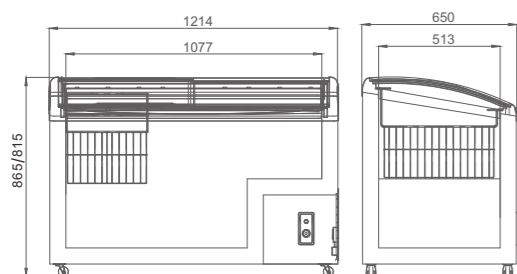

WD4-297H / WD4-337H

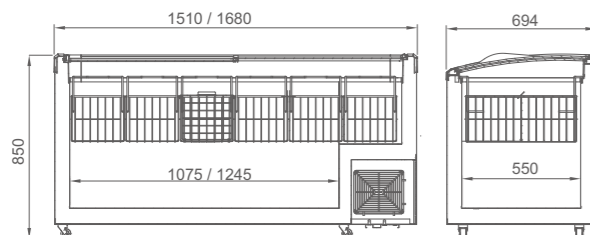

WD4-446 / WD4-536

## Product Features

- Plug ready
- Flexible arrangement
- Reliable and functional
- Robust for heavy duty use
- Ideal height Excellent product display
- Selected by leading companies in the frozen food sector and super markets

Model	Product Dimension WxDxH(mm)			Packing Dimension WxDxH(mm)			Temperature	Capacity (Litre)	Shelf Quantity	40HQ Loading
WD4-297H	1214	650	815	1274	710	910	t≤-18°C	297	3	75
WD4-337H			865					970		
WD4-466	1510	694	850	1566	750	885		466	6	66
WD4-536			1680					1736		

# DEEP FREEZER

-40°C / -60°C

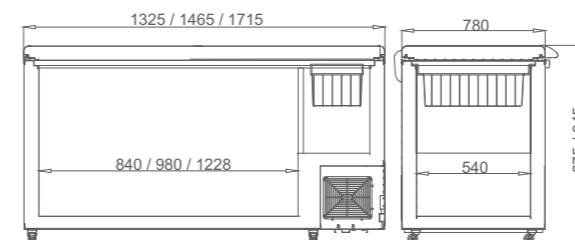

DW-40W359 / DW-40W459 / DW-40W559

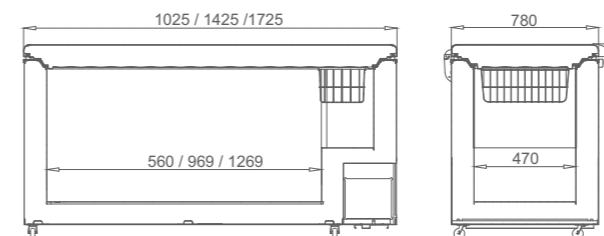

DW-60W206 / DW-60W325 / DW-60W425

## Product Features

- Plug ready
- Digital thermostat
- Reliable and functional
- Deal for Seafood storage
- Robust for heavy duty use
- Selected by leading companies in the frozen food sector

Model	Product Dimension WxDxH(mm)		Packing Dimension WxDxH(mm)		Temperature	Capacity (Litre)	Doors	40HQ Loading
DW-40W359	1325	875	1385	960	t≤-40°C	357	1	46
DW-40W459	1465	945	1525	1030		455		44
DW-40W559	1715	945	1775	1030		540	2	38
DW-60W206	1025	905	1085	990	t≤-60°C	206	1	66
DW-60W325	1425		1485			325		48
DW-60W425	1725		1785			425		42

**CHEST FREEZER**  
80% REDUCE-FROST DESIGN

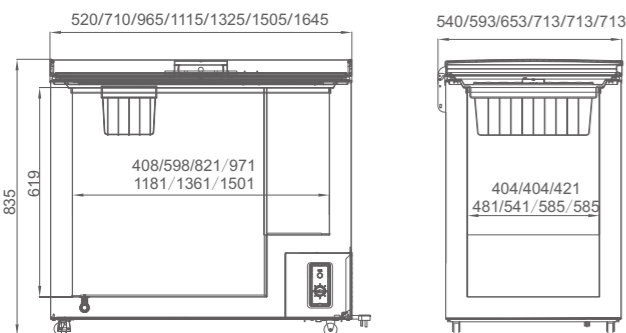

BD-103K/BD-155K/BD-218K/BD-299K/BD-399K/BD-508K/BD-580K

**Product Features**

- Plug ready
- Less ice design
- Reliable and functional
- Robust for heavy duty use
- Ideal for conservation of frozen food and ice cream
- Selected from leading companies in the ice cream and frozen food industry

Model	Product Dimension WxDxH(mm)		Packing Dimension WxDxH(mm)			Temperature	Capacity (Litre)	Doors	40HQ Loading
BD-103K	520	835	560	885	880				
BD-155K	710		575						
BD-218K	965		620						
BD-299K	1115		680						
BD-399K	1325		745						
BD-508K	1505		745						
BD-580K	1645		1706						

**CHEST FREEZER**

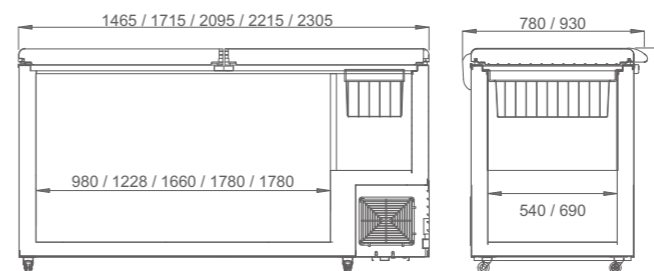

BD-550 / BD-650 / BD-850 / BD-1000 / BD-1250

**Product Features**

- Plug ready
- Reliable and functional
- Robust for heavy duty use
- Ideal for conservation of frozen food and ice cream
- Selected from leading companies in the ice cream and frozen food industry

Model	Product Dimension WxDxH(mm)		Packing Dimension WxDxH(mm)			Temperature	Capacity (Litre)	Doors	40HQ Loading
BD-550	1465	835	1525	885	880				
BD-650	1715		1775						
BD-850	2095		2155						
BD-1000	2215		2275						
BD-1250	2305		2365						
	930		935						

# CHEST FREEZER

CHEST FREEZER

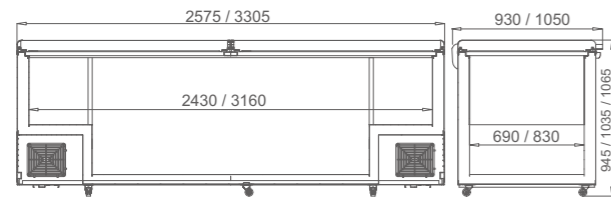

BD-1500 / BD-1750 / BD-2000

## Product Features

- Adjustable baskets
- Hi-efficiency compressor
- Large storage volume
- 100% CFC free polyurethane foam

Model	Product Dimension WxDxH(mm)			Packing Dimension WxDxH(mm)			Temperature	Capacity (Litre)	Doors	40HQ Loading
BD-1500	2575	930	945	2635	935	1030	0°C ≤ t ≤ 10°C or t ≤ -25°C	1043	2	16
BD-1750		1050	1035		1055	1160		1324		
BD-2000		3305	930		1065	3365		935		

# CHEST FREEZER

## 304 STAINLESS STEEL INTERIOR



CHEST FREEZER

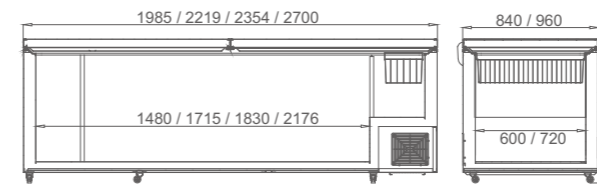

BD-730 / BD-830 / BD-1030 / BD-1230

## Product Features

- Plug ready
- Big capacity
- Reliable and functional
- Robust for heavy duty use
- Stainless Steel 304 interior
- Ideal for conservation of frozen food
- Selected from leading companies in the ice cream and frozen food industry

Model	Product Dimension WxDxH(mm)			Packing Dimension WxDxH(mm)			Temperature	Capacity (Litre)	Doors	40HQ Loading
BD-730	1985	840	935	2040	860	1030	0°C ≤ t ≤ 10°C or t ≤ -25°C	730	2	26
BD-830	2219			2275				801		
BD-1030	2354	960		2410	1030			16		
BD-1230	2700			2755	1230					

# FLAT GLASS TOP CHEST FREEZER

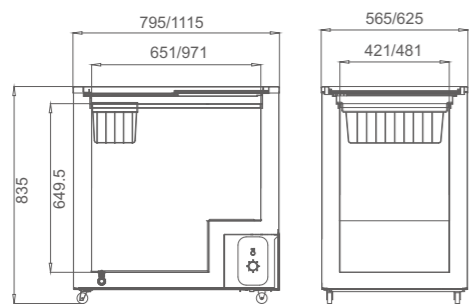

WD4-165K / WD4-275K

## Product Features

- Plug ready
- Reliable and functional
- Optimum product visibility
- Ideal for promoting frozen products
- Ideal for heavy duty and outdoors use
- Selected by leading companies in the ice cream sector

Model	Product Dimension WxDxH(mm)		Packing Dimension WxDxH(mm)			Temperature	Capacity (Litre)	Shelf Quantity	40HQ Loading
WD-165K	795	565	835	850	620	0°C ≤ t ≤ 10°C or t ≤ -18°C	165	1	143
WD-275K	1115	625		1170	680		275		94

# FLAT GLASS TOP CHEST FREEZER



WD-550/WD-650

WD-750

## Product Features

- Plug ready
- Ideal for heavy duty
- Reliable and functional
- Optimum product visibility
- Deal for promoting frozen products
- Selected by leading companies in the ice cream sector

Model	Product Dimension WxDxH(mm)			Packing Dimension WxDxH(mm)			Temperature	Capacity (Litre)	Shelf Quantity	40HQ Loading
WD-400	1375	635	880	1435	695	940	0°C ≤ t ≤ 10°C or t ≤ -18°C	295	1	66
WD-550	1445	665	805	1505	730	890		416		61
WD-650	1695			1755				506		51
WD-750	2075			2135				596	2	45

**MEAT DISPLAY REFRIGERATOR**  
FAN COOLING

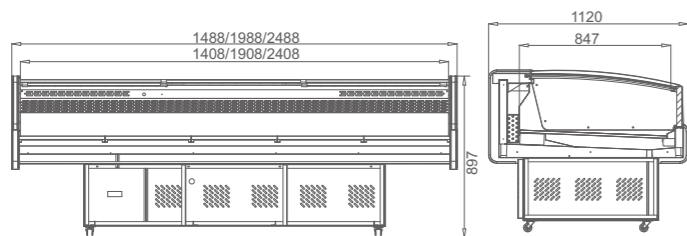

DLCD-1.5PF-B / DLCD-2.0PF-B / DLCD-2.5PF-B

**Product Features**

- Digital thermostat
- Automatic defrost
- 100% CFC free polyurethane foam

**MEAT DISPLAY REFRIGERATOR**  
STATIC COOLING

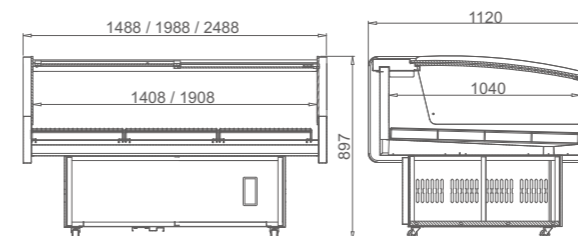

DLCD-1.5T / DLCD-2.0T / DLCD-2.5T

**Product Features**

- Large storage volume
- Mechanical thermostat
- 100% CFC free polyurethane foam

Model	Product Dimension WxDxH(mm)			Packing Dimension WxDxH(mm)			Temperature	Capacity (Litre)	Shelf Quantity	40HQ Loading
DLCD-1.5PF-B	1488	1120	897	1620	1230	1000	2°C≤t≤8°C	220	3	18
DLCD-2.0PF-B	1988			2120				4		
DLCD-2.5PF-B	2488			2620				5		

Model	Product Dimension WxDxH(mm)			Packing Dimension WxDxH(mm)			Temperature	Capacity (Litre)	Shelf Quantity	40HQ Loading
DLCD-1.5T	1488	1120	897	1620	1230	1000	2°C≤t≤8°C	420	3	18
DLCD-2.0T	1988			2120				4		
DLCD-2.5T	2488			2620				5		

**REACH-IN  
REFRIGERATOR / FREEZER**

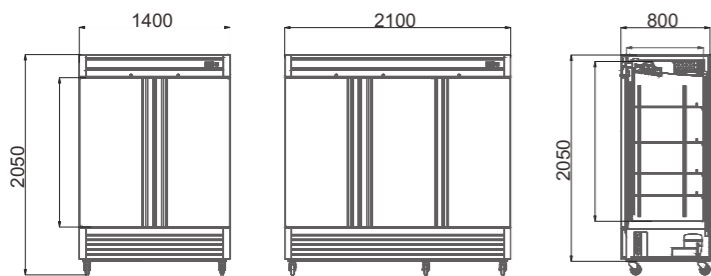

SL55R / SL55F / SL83R / SL83F

**Product Features**

- Adjustable, heavy duty shelves
- Stainless steel interior and exterior
- Rounded cabinet corner for easy cleaning
- Self closing doors with stay open feature
- Bottom-mounted compressor for better heat evaporation
- Digital temperature controller with automatic defrost system

Model	Product Dimension WxDxH(mm)			Packing Dimension WxDxH(mm)			Temperature	Capacity (Litre)	Shelf Quantity	40HQ Loading
SL55R	1400	800	2050	1450	850	2150	0°C≤t≤10°C	1226	6	21
SL55F							-18°C≤t≤10°C	1226		
SL83R	2100	800	2050	2150	850	2150	0°C≤t≤10°C	1882	9	13
SL83F							-18°C≤t≤10°C	1882		

**COMMERCIAL SANDWICH AND  
SALAD PREPARATION REFRIGERATOR**

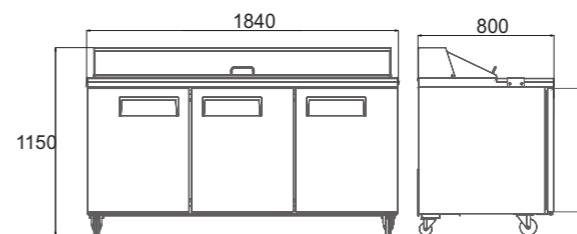

SLSP72

**Product Features**

- Heavy duty shelves
- Back mounted compressor
- Stainless steel interior and exterior
- Rounded cabinet corner for easy cleaning
- Self closing doors with stay open feature
- Digital temperature controller with automatic defrost system

Model	Product Dimension WxDxH(mm)			Packing Dimension WxDxH(mm)			Temperature	Capacity (Litre)	Shelf Quantity	40HQ Loading	
SLSP29	740	800	1150	850	914	1228	0°C≤t≤10°C	206	1	56	
SLSP48	1225			1333				364			2
SLSP60	1529			1635				465	28		
SLSP72	1841			1951				562		3	

## COMMERCIAL SANDWICH AND SALAD PREPARATION REFRIGERATOR



SLSP29M / SLSP48M / SLSP60M / SLSP72M

### Product Features

- Heavy duty shelves
- Back mounted compressor
- Stainless steel interior and exterior
- Rounded cabinet corner for easy cleaning
- Self closing doors with stay open feature
- Digital temperature controller with automatic defrost system

Model	Product Dimension WxDxH(mm)		Packing Dimension WxDxH(mm)		Temperature	Capacity (Litre)	Shelf Quantity	40HQ Loading	
SLSP29M	740	800	1160	850	0°C≤t≤10°C	206	1	56	
SLSP48M	1225			1333		914	364	2	40
SLSP60M	1529			1635			465		28
SLSP72M	1841			1951		562	3	26	

## GLASS DOOR MERCHANDISER REFRIGERATOR / FREEZER



GLD54R / GLD54F / GLD81R / GLD81F

### Product Features

- Auto defrost
- Tempered glass
- Adjustable shelves
- Fan assisted cooling
- Fan assisted condenser
- Replaceable door gasket
- Interior and canopy LED light with switch

Model	Product Dimension WxDxH(mm)		Packing Dimension WxDxH(mm)		Temperature	Capacity (Litre)	Shelf Quantity	40HQ Loading	
GLD54R	1380	800	2050	1430	0°C≤t≤10°C	1170	8	21	
GLD81R	2080			2130		835			1800
GLD54F	1380			1430	2120		t≤-22°C	1115	12
GLD81F	2080			2130		1735			